

OVERVIEW OF POSITION FEEDBACK SENSORS AVAILABLE FOR BRIDGES AND OTHER HMS PROJECTS: FROM ELECTROMECHANICAL TO ELECTRONIC TO FIBER OPTICS

BY: Dennis Horwitz, Micronor Inc.
3483 Old Conejo Rd, Suite 203
Newbury Park, CA 93003 USA
Tel (805) 499-0114, Fax (805) 499-6585
dennis.horwitz@micronor.com

Abstract

When bridges and other large movable structures are design or upgraded, there are a multitude of position feedback sensor options that reflect a very broad range of technologies – from electromechanical to electronic to optoelectronic to state-of-the-art fiber optics. Decisions are usually based on a multitude of factors – including environmental, reliability, redundancy, safety, and reliability. These applications can also reflect a preponderance for conservatism versus state-of-the-art, in a spirited clash of the old school versus new school of engineering.

This paper overviews the more common position sensor options and references actual case studies to illustrate the diverse solutions available and the reasons behind the decisions. The cases reviewed include bascule bridge, lift bridge, hydroelectric dam gate and aerial cable car.

Introduction

The control of Heavy Moveable Structures (HMS) typically involves monitoring the position and/or speed of movement of the structure - be it a bridge leaf, dam gate or vehicle. As shown in Figure 1, The degree of motion can vary by application and design.



Figure 1. Examples of bridges with different degrees of motion.

Motion takes place via an actuation system. A typical motor drive actuation system can be modeled as shown in Figure 2. An actuation system has these features:

- Motor or actuators can be electric, hydraulic or pneumatic.
- Commutation control of an electric motor can be accomplished via position sensor or sensorless V/I feedback. Sensor based feedback tends to provide more precision control.
- Actuation usually requires converting rotary motion of a motor to the linear or angular motion required of the structure (lift or rotate bridge structure, raise/lower gate, feed cable for aerial tram, etc).
- Position sensor allows direct monitoring of the position/speed of the HMS independent of the feedback sensor used for directly controlling the motor. However, some applications can use one sensor for both controlling the motor as well as monitoring position of the structure.

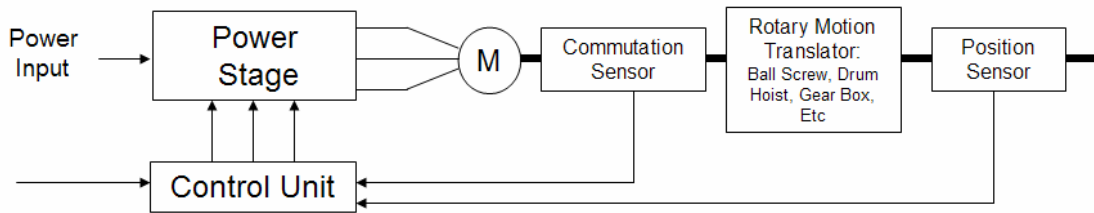

Figure 2. Block diagram of typical actuation system.

Technology cuts a wide swath when it comes to position/speed sensors. Electromechanical solutions (requiring no external electronics) include discrete limit switches, geared limit switches and selsyns (synchronous receivers/transmitters). Electronic and optoelectronic solutions can include magnetic Hall sensors, optical proximity sensors, resolvers and digital encoders. At the “bleeding edge of technology”, fiber optic encoders offer the advantages of passive operation and EMI immunity (like limit switches), superior environmental performance (like resolvers) and long reach (which is why telecom networks use fiber optics for long distance communications). Many systems choose to implement a hybrid solution – for example, combining encoders for advanced electric motor drive control along with electromechanical limit switches for fail-safe backup.

Using real world HMS examples and case studies, we'll discuss some of the most common as well as state-of-the-art position sensors as well as their advantages and disadvantages:

- Geared limit switch (example: dam gate hoist)
- Selsyns (a.k.a. synchros) (example: bascule bridge)
- Resolver vs Optical Rotary Encoder vs Fiber Optic Encoder (example: lift bridge)

Case #1 – Geared Limit Switch (GLS) for Cable Drum Gate Hoist

Rotary cam switches are the most basic and direct form of position feedback - or failsafe backup control. No electronics to power. No computer to program. No software to maintain. Unaffected by EMI or lightning. Simple, rugged, robust and reliable. As shown in Figure 3, cams are mechanically programmed to physically activate/deactivate one or more microswitches corresponding to specific payout positions of the cable. Typical applications include chain- or cable-driven drum hoist mechanisms used on lift bridges, dam gates and cranes.

For this case study, we'll focus on the unique requirements of a geared limit switch (GLS) for controlling the gate on a hydroelectric dam in western Canada. The requirements called specifically for electromechanical switches as part of a retrofit of the existing structure – no encoders or similar modern rotary sensors were desired by engineering. A drum hoist would use 55 turns for total of 113.375 ft of gate travel. Typically we like to provide an extra 30° of headroom to the gear ratio as headroom for the upper limit setting so that the actual gear ratio was chosen to be 66:1. Thus, 66 revolutions of the drum corresponded to a full revolution of the cam. Thus a gear ratio of 66:1 was chosen to provide the necessary mechanical headroom.

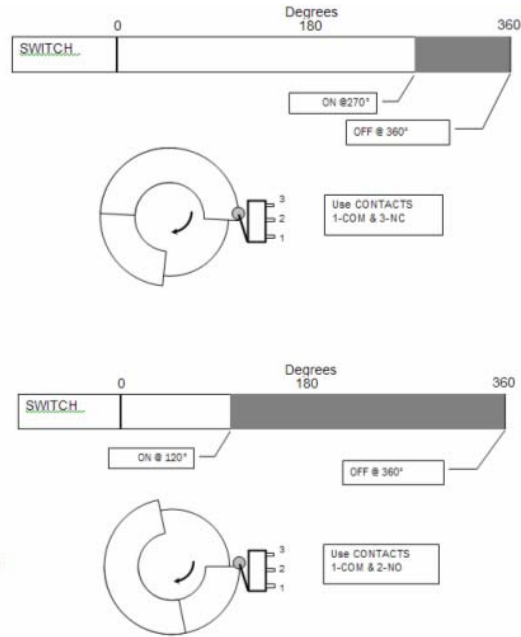
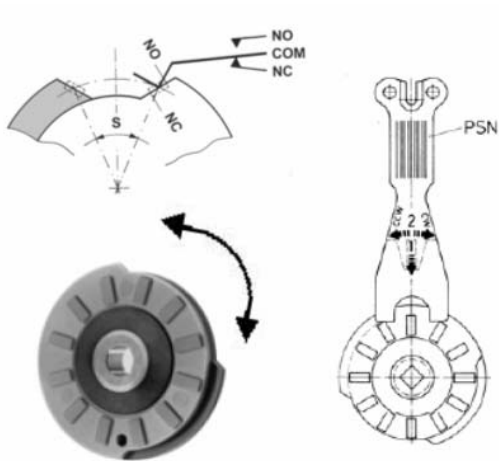

A double cam (two 180° cams joined back-to-back) can offer a actuation range of 4° to 356° by using the proper contact connections.

Figure 3. How A Rotary Cam Switch Works

The switching diagram in the righthand corner of Figure 4 shows the gate's cam settings corresponding to linear feet. These values would need to be divided by 113.375 and then multiplied 55 to arrive at the actual cam settings in turns. A single-gear GLS cam solution would work fine for individual cam settings of at least 5° spacing (calculated to be 1.8 ft). However, the CRK/CLD and 95%/HO settings for this application are only 3" and 1.2 ft apart, respectively - too close to accurately set the cams with a conventional single-gear GLS solution.

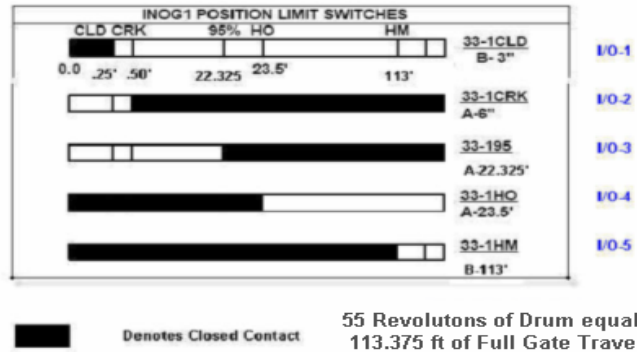
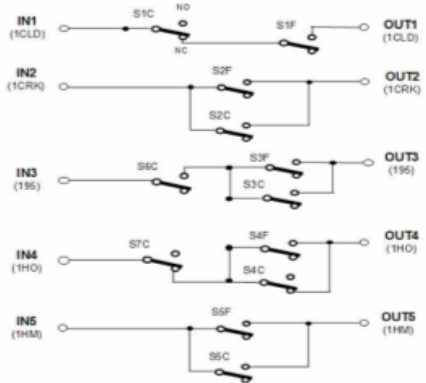
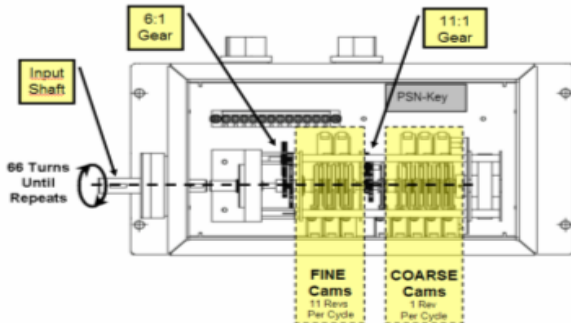

Figure 4. Coarse/Fine Limit Switch solution for Canadian hydroelectric dam gate control.

To obtain <1" setting accuracy, a novel Coarse/Fine cam switch mechanism was developed where the Fine cam gear ratio = 1:6 and the Coarse cam gear ratio = 66:1. A picture and switch schematic of the actual unit is also shown in Figure 4. The two-stage, Coarse/Fine limit switch arrangement is a unique solution for electromechanical cam switch applications requiring high precision, accuracy and repeatability. Figure 5 illustrates this concept where the repeating nature of the Fine cam setting is logically AND'd with a Coarse switch. The example shows the actual calculations and cam switch settings for the HO (Normal Operating) position of the dam gate. The other channels are variations of this approach.

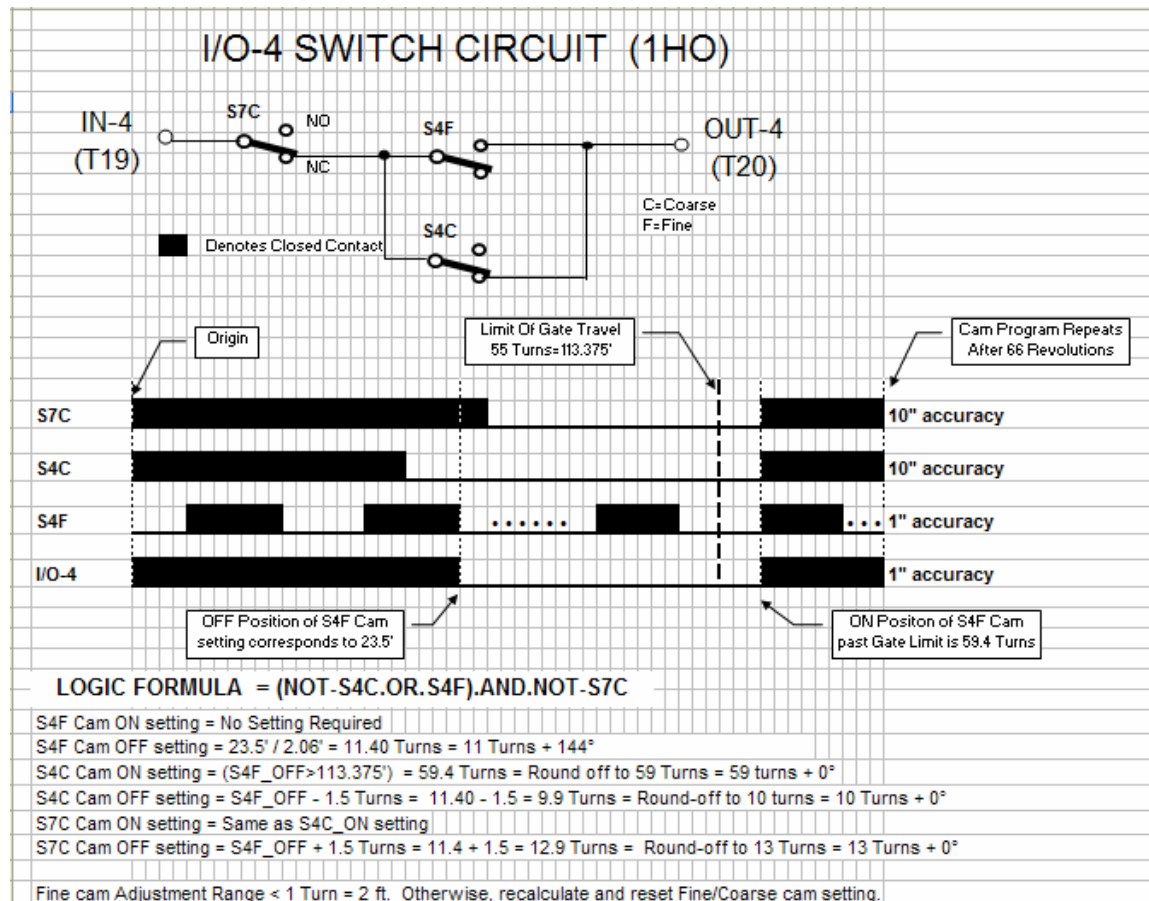

Figure 5. Example of Coarse/Fine cam programming for HO circuit (Normal Operating Position).

Case #2 – Selsyn Control for Bascule Bridge

Developed in the 1920's, a synchro or "selsyn" (stands for "self synchronization") is a type of rotary electrical transformer that is used for measuring the angle of a rotating machine such as an antenna platform, bridge leaf or steering on a ship. As shown in Figure 6, a selsyn is much like an electric motor. The primary windings of both the transmitter and receiver selsyns are fed through a common AC supply. The secondary windings are interconnected. When the primaries are energized, the induced voltages in the secondary winding from a common electrical circuit and current is circulated. This current creates a synchronizing torque so that the rotor of the receiver chases that of the transmitter and locks with it at all speeds and position. Thus the receiver will continuously monitor the position and speed of the equipment to which the transmitter is coupled. Hence, mounting a wiper on the receiver's rotor would provide an direct analog display of the transmitter's position.

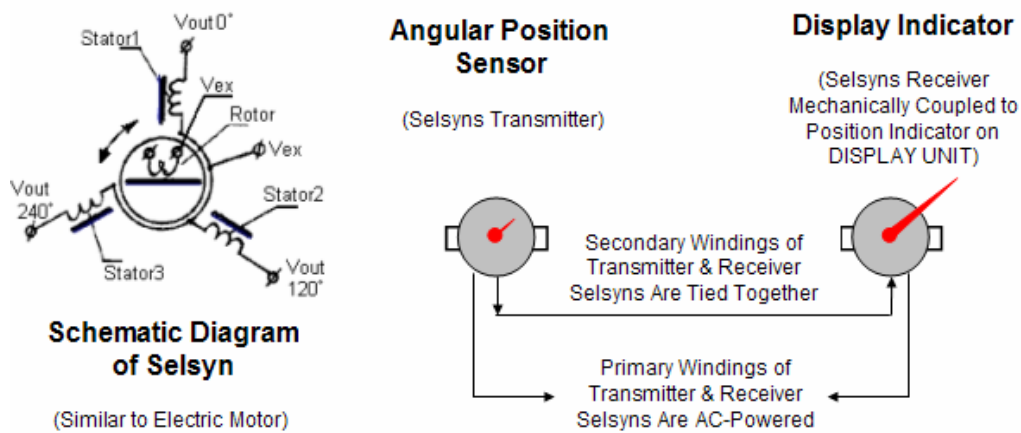

Figure 6. How A Selsyn Works.

For a project upgrading three bascule bridges in the Sacramento (CA) delta region, the customer dictated the use of selsyns for displaying the angular position of the two leaf sections in the control room. To the engineers, this was tried and true and preferred technology despite the higher cost, long lead time and single source for selsyns - versus rotary encoders.

The trunion unit was actually a hybrid implementation – incorporating both selsyn transmitter (drives display) and rotary limit switches (control). Figure 7 shows the hybrid Trunion unit (selsyn transmitter and GLS) and Display (selsyn receivers with wiper) used in the project. A separate Lock GLS unit (not shown) provided position feedback for locking rod which became engaged when the leaves were in the full down position.



Figure 7. Sacramento area bascule bridges were upgraded with new selsyn-based position display system (with LED backlight) and new rotary limit switch controls.

Case #3 – Resolvers vs Optical Encoders vs Fiber Optic Encoders (Lift Bridge)

A **resolver** is a rotary transformer where the magnitude of the energy through the resolver windings varies sinusoidally as the shaft rotates. As shown in Figure 8, A resolver control transmitter has one primary winding, the Reference Winding, and two secondary windings, the SIN and COS Windings. The SIN and COS Windings are mechanically displaced 90 degrees from each other. In a brushless resolver, energy is supplied to the Reference Winding (rotor) through a rotary transformer. A resolver requires an external R/D (resolver-to-digital) interface,



Figure 8. Diagram and examples of resolvers

An **optical rotary encoder** is an optoelectronic device used to convert the angular position of a shaft or axle to an analog or digital code. The optical encoder's disc is made of glass with transparent and opaque areas. As shown in

Figure 9, a light source and photo detector array reads the optical pattern that results from the disc's position at any one time. This code is read by an embedded processor to process the encoders signals and produce a digital output. There are two types of optical rotary encoders – incremental and absolute.

- An **incremental** rotary encoder, also known as a quadrature encoder or a relative rotary encoder, has two outputs called quadrature outputs. These A and B quadrature outputs are 90° apart. Sometimes there is a third output called an index which is outputted once per revolution. Unlike absolute encoders, these encoders are much less expensive. The motor drive or actuator system will count the pulses to determine velocity and position.
- An **absolute encoder** incorporates a glass code disc which contains a binary or gray code scheme which provides a unique output for any position. An embedded processor reads this code and provides either an analog or digital output. The digital output can be parallel binary, RS485, SSI, Profibus, CANopen or other type of high level field bus interface. Some absolute encoders are designed to output position as an analog output, typical 0-10V or 4-20mA.

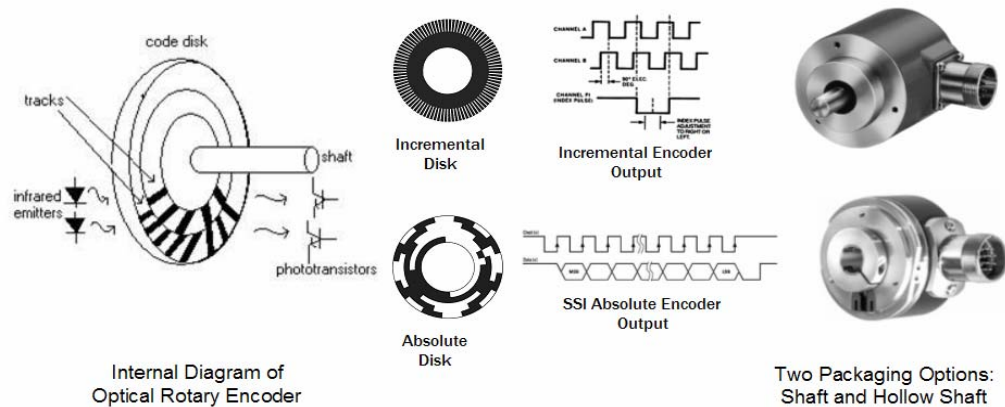

Figure 9. How an optical rotary encoder works

A technological variation of the optical encoder is the **fiber optic encoder** (see **Error! Reference source not found.**). To describe the concept in the most simplest terms, the optoelectronics are shifted from the sensor to the remote encoder interface module using a wavelength division multiplexing technique over a single fiber. Two wavelengths are used – each corresponding to either the A or B quadrature signal – multiplexed (co-existing) over the same fiber. The sensor is an all-optical, totally passive device.

Consisting only of the code wheel and optical head, its minimalist, low component design makes it more robust and reliable than the complex, multicomponent design of the optical rotary encoder. Being fiber optic based, the fiber optic encoder offers EMI immunity and longest link lengths (up to 2000m) – unmatched by any other type of position sensor. The fiber optic encoder is also offered in both incremental and absolute models as well as shafted and hollow shaft configurations.

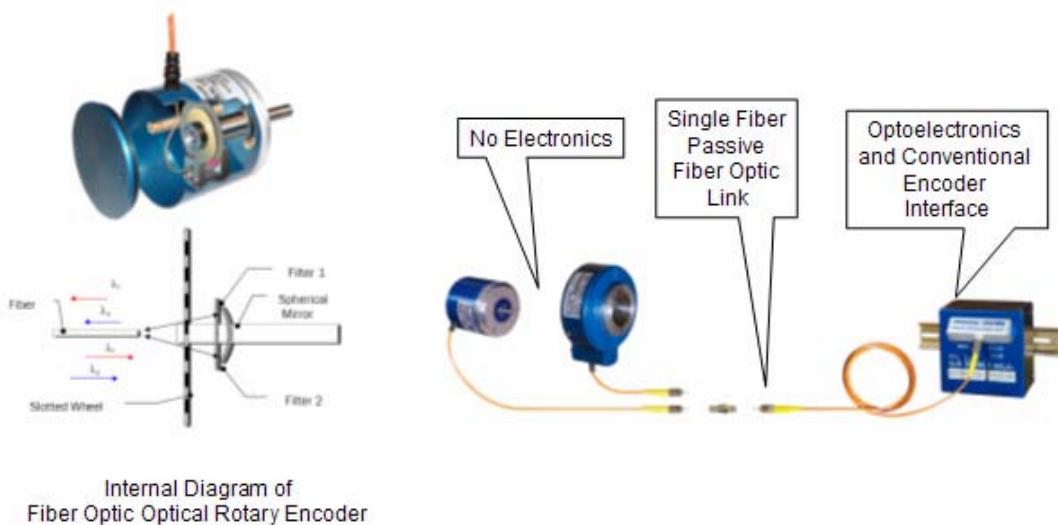

Figure 10. How a fiber optic rotary encoder works.

The upgrade of the New Young's Bay Bridge (Astoria, OR – shown in Figure 12) involved retrofitting the lift mechanism with new servo drives. The motion and position of both ends of the lift drive system must be precisely synchronized. Another consideration was that the wiring connecting the Near end control cabinet and the remote Far end had to be laid underwater and reach about 200-300 ft. The feedback signals needed to be completely noise free – completely unaffected even by the drive's high voltage power cables running alongside the feedback signals cable. A comparison of the cabling requirements and distance capabilities of resolvers and encoders is shown in Figure 11.

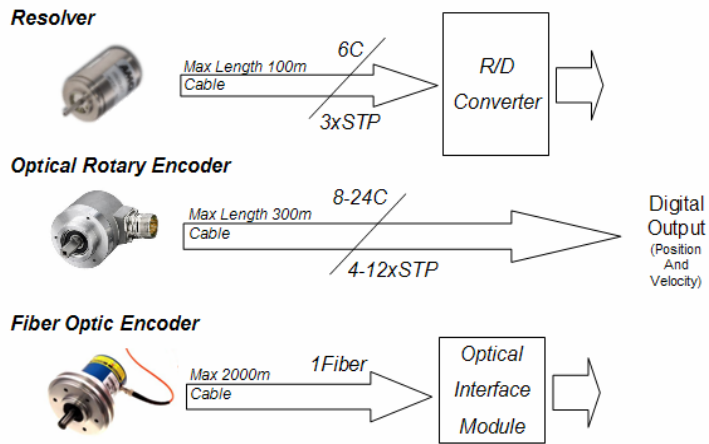

Figure 11. Comparison of resolver and encoder interface configurations and distance limitations.

Resolvers were ruled out due to their analog nature, susceptibility to noise and limited reach. Multiconductor copper cabling for the feedback loop was also considered a noise liability and a fiber optic solution was preferred. The customer's engineering staff was open to any and all feedback solutions – without any technological bias.

The solution was to use similar incremental rotary encoders on both ends. A conventional 1024ppr incremental optical rotary encoder (for cost reasons) was used on the Near end - while the Far end incorporated a 1024ppr fiber optic incremental encoder. At the control end, the electrical A/B quadrature outputs of the two encoders (one being optical and the other being fiber optic) would be transparent to the servodrives's feedback inputs. The control system synchronizes the speed and position of the lift motion by monitoring and comparing the outputs of the two encoders.



New Young's Bay Bridge (Astoria, OR) combines Optical Rotary Encoder on Near End with Fiber Optic Encoder on Far End (linked via underwater fiber optic cable). Encoders provide velocity feedback to servomotors for synchronizing both ends of lift section.

Figure 12. New Young's Bay Bridge was upgraded with both optical and fiber optic encoders.

Conclusion

The following table summarizes the advantage and disadvantages of the 5 type of position feedback sensors discussed in this paper. In addition, every application typically dictates preferred type of position sensor depending whether it's a new installation (favors latest technology), a upgrade/retrofit (favors existing or mature technology-usually not the latest) or repair (favors existing technology):

Type	Geared Limit Switch	Selsyns (Synchros)	Resolver	Optical Rotary Encoder	Fiber Optic Rotary Encoder
Classification	Electromechanical	Electrical	Electrical (requires remote R/D interface)	Optoelectronic	All Optical
Years In Use	100+ years	50+ years	50+ years	10+ years	5 years
Multiple Suppliers?	Few	One	Few	Many	Few
Active or Passive Sensor?	Passive	Active	Semi-Active	Active	Passive
Temperature Range	-40/+85°C	-0/+55°C	-55/+125°C (+150°C)	-20/+70°C (+100°C)	-60/+150°C
External Interface Required?	No	Yes. Requires Selsyn RCVR.	Yes	No	Yes
Discrete or Continuous Position?	Discrete	Continuous	Continuous	Continuous	Continuous
Sensitive to EMI?	No	No	Yes	Yes	No
Remote Sensor Power Required?	No	Yes	No	Yes	No
No of Conductors Required?	2-3C per switch	5C	6 wires (STP preferred)	8-12C for incremental encoders, SSI and other field bus interfaces. (STP preferred)	1 fiber
Maximum Distance	100m	100m	100m	300-500m (depending on type of output drivers and EMI environment)	2000m
Cost	Medium	High	Medium	Low-Medium for Incremental Encoders. Medium-High Cost for Absolute Encoders.	High

Author's Biography

Dennis Horwitz received his M.S.E.E. from UCLA and has over 25 years experience in R&D, sales and marketing of fiber optic test equipment and components. He was co-founder of two successful start-ups in fiber optic test and measurement: Photodyne Inc and Rifocs Corp. He is an IEEE Senior member and actively involved in fiber optic standards committees across various markets (ARINC, IEC, IEEE, ISA, SAE and TIA). Mr. Horwitz is the instructor for the popular short courses – “Basic Fiber Optics for Absolute Beginners” and “Fiber Optics For Engineers Designing For Military, Aerospace, Shipboard and Industrial Harsh Environmental Applications” - presented at the annual OFC/NFOEC conference. He is currently co-owner and VP-Sales & Marketing for Micronor Inc., serving the industrial automation, military/aerospace and similar harsh environment motion control markets.